



**DURHAM - DUPLEX**

**SHEFFIELD • ENGLAND**

*Razor sharp since 1910*

**Industrial Knife Manufacturer**



**DURHAM - DUPLEX**

**S**®  
MADE IN  
SHEFFIELD





**SHEFFIELD • ENGLAND**



**Industrial Blade, Machine Knife and Hand Knife Manufacturers**



**Company Profile**

Durham-Duplex is a world leader in the design, manufacture and distribution of machine knives and industrial razor blades. As a family owned manufacturing company based in Sheffield, England since 1910, **Durham-Duplex** is very proud of Its *“Made in Sheffield”* pedigree and now sells to over 40 countries direct and through our dedicated international distributors. Thus over a century after the first blade was sold Durham Duplex’s quality products/blades are still sought after global commodities and the company is looking forward to the next 100 years of innovation and excellence.

**Quality**

Durham-Duplex has a time proven quality assurance program with an experienced inspection team at each facility. This is supported by our own ISO based *“in line”* quality assurance regime that ensures that all knives are continually checked in production to ensure the highest standards of quality and accuracy.

**Service Ethos**

Durham-Duplex values its customers and has a large and experienced staff to ensure personal and efficient service.

*Call now to experience the Durham-Duplex difference.*

**Tel: +44 (0) 114 2432 313**

**Fax: +44 (0) 114 2444 329**

**sales@durham-duplex.co.uk**

**export@durham-duplex.com**

**www.durham-duplex.com**



***Razor sharp since 1910***



# Machine Knives

Durham-Duplex provides a comprehensive stock of punches, straight, circular and serrated machine knives, manufactured from carbon, stainless, alloy, high speed and powder steels to fulfil the modern factory's requirements in almost every industrial sector. Furthermore, our extensive technical experience is always available to assist in custom knife design, upgrading and problem solving.

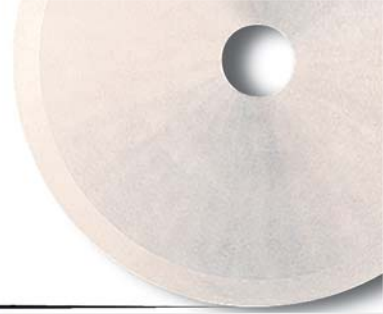

We stock an extensive range of precision ground serrated knives in parallel, tapered and apex profiles, available with standard, tear notch or easy open tooth configurations to complement all modern packaging equipment.

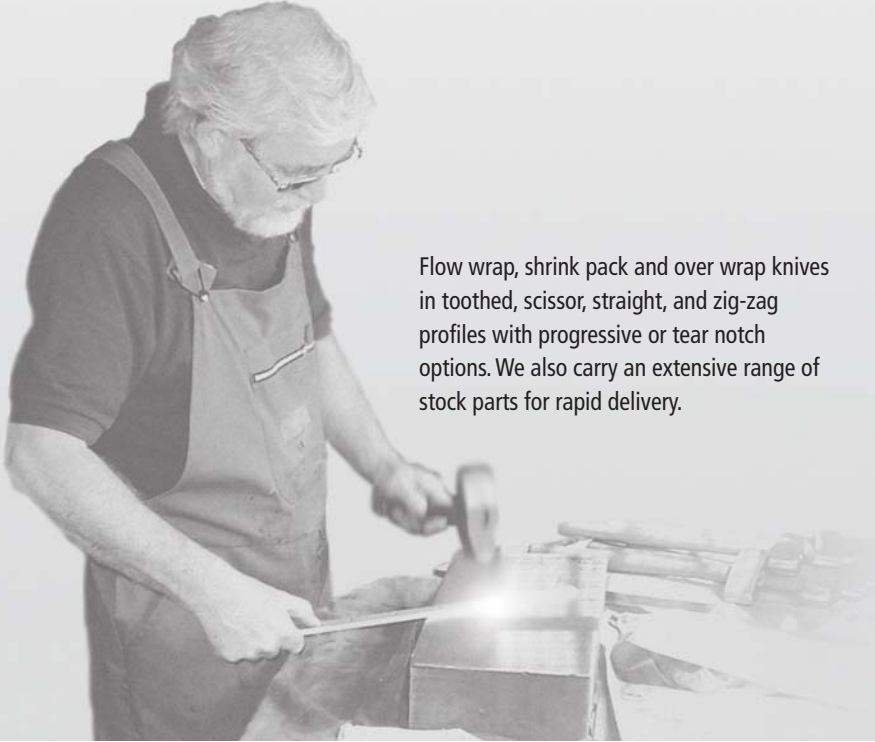

Flow wrap, shrink pack and over wrap knives in toothed, scissor, straight, and zig-zag profiles with progressive or tear notch options. We also carry an extensive range of stock parts for rapid delivery.

## Vertical Packaging Knives



## Food Processing

## Food Packaging



The demands of the food industry require an extra special touch. Whether processing or packaging food products customers require a blade with clean, corrosion resistant edges and traceability. To meet this industry standard **Durham-Duplex** offers the highest grade magnetic stainless and high chrome tool steels across the majority of our knife range.

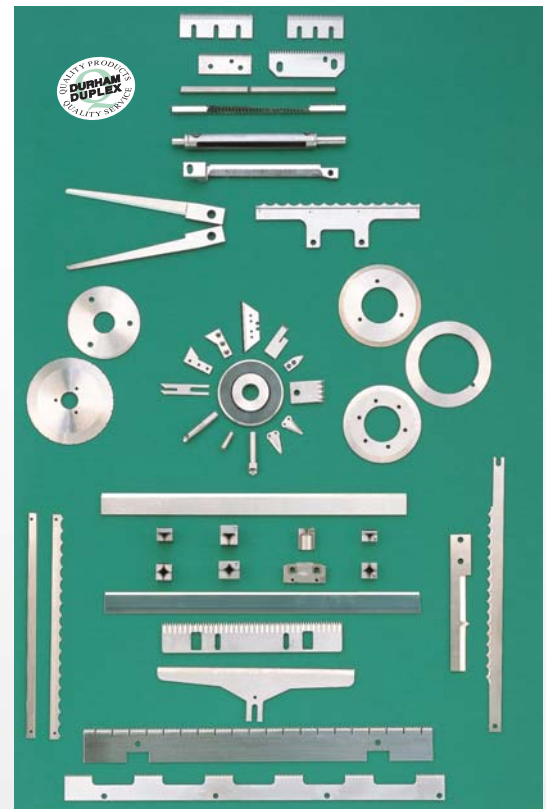

# Machine Knives

## Vacuum Packaging & Case Taping

## Printing & Graphics

Durham-Duplex has a wide range of knives for use in the print and sealing areas. These include high precision vacuum punches, fly knives, serrated web press knives, film cut off knives, core cutters, crush cutters, dish slitters, tape sealers and bottom knives.

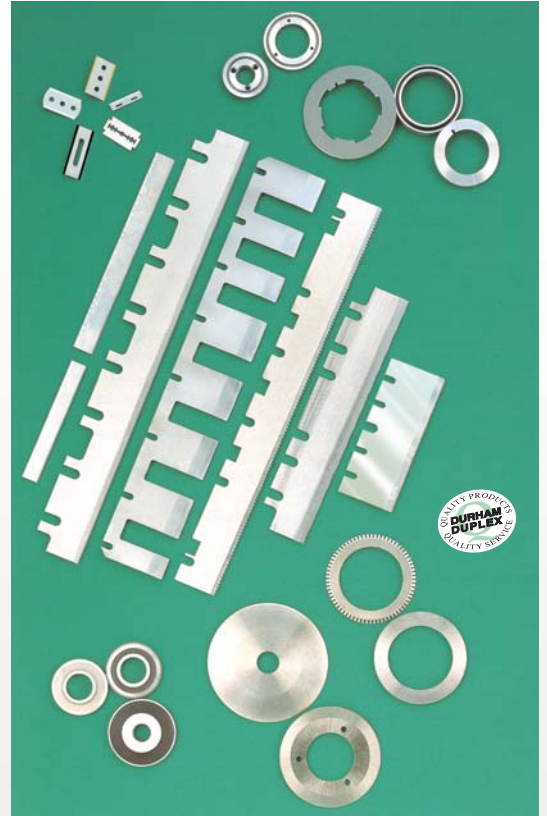
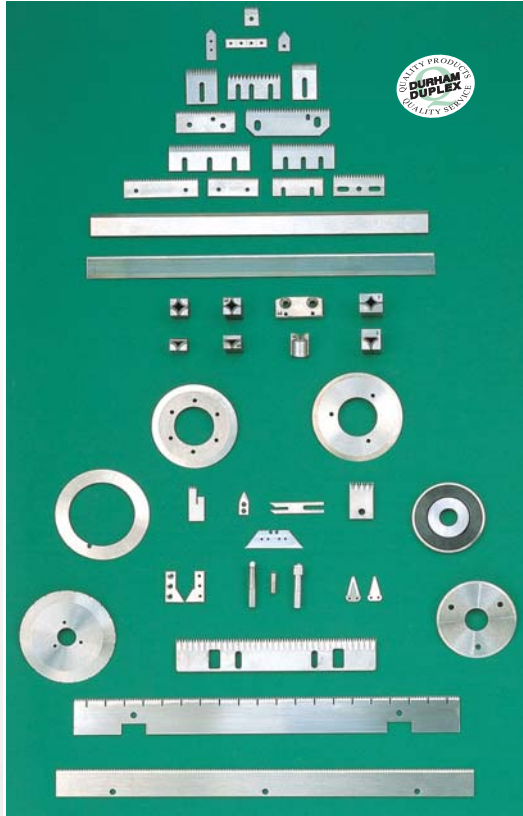

## Fibre Processing, Plastic Film & Paper Converting

## Polythene & Paper Bag & Sack Production

Converting man made film, foil and fibre products requires an array of cutting requirements to effectively slit, perforate, chop and recycle the end product. **Durham-Duplex**'s innovative and unique range of industrial razor blades are used by the world's largest manufacturers to ensure the consistency and quality of their products. Additionally our investment in innovation means that we are always at the forefront of technology when it comes to preparing machine knives for processing the material into bags, sacks, tape, labels and sachets.





# Machine Knives

## Specialised Manufacture of Unique Machine Knives

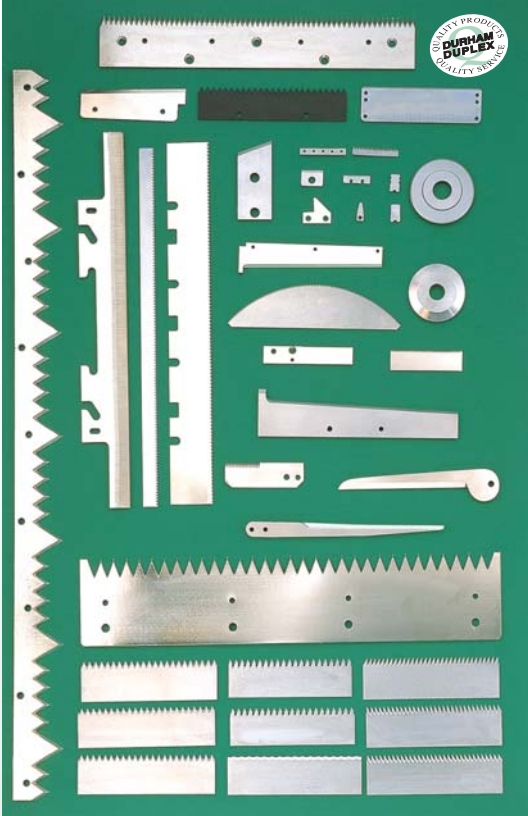

Durham-Duplex's bespoke manufacturing facilities enable the company to develop prototypes and competitive short run products for machine builders, end users and multinationals alike. Investment in modern manufacturing equipment means that production runs of up to one million blades can be delivered on time and correct to specifications.

Straights, zig zags, flat circles, punches, coiled strip, dish circulars, serrated strip, granulators, pelletisers, tube cutters, serrated pieces are all available so if it cuts, slits, slices, pierces, perforates, chops, chips, dices, scrapes, mixes, folds, macerates or creases then we can probably help you improve it.

## Durham-Duplex's Range of Specialist Blades for converting Film/Foil



**Film Foil & Converting**  
Modern films and foils often have high levels of recycled content and contain highly abrasive particles that greatly increased friction heat and reduce slit edge quality. **Durham-Duplex** offers a comprehensive range of solutions from low cost PVD coatings (TiN, Ceramic and XCD) on both carbon and stainless bodies for short run lines through to HSS, solid tungsten carbide and solid ceramic for continuous 24/7 slitting.

**Circular Knives** - from core cutters to dish slitters, bottom knives to multi edge, zig zag edge and sharp, hollow ground, sharp or radius'd from 28mm to 500mm + **Durham-Duplex** offer a comprehensive range of carbon, stainless, high chrome and high speed steels plus more exotic ASP, tungsten carbide and ceramic materials where necessary.



# Safety Knives and Hand Knives

The Durham-Duplex range of hand held utility knives are designed for today's environment. Strong, durable, uncomplicated and effective whilst remaining easy on the pocket. Where safety is an issue we have a multitude of different approaches from spring loaded designs to hidden blades and restricted apertures to ensure that every job can be completed quickly and safely without damage to product or person.



## Personna Range

1. B201 106 A01 (Branded Personna)
2. B201 104 A01 (Gem)
3. B204 020 A01 (Personna)
4. New Single Dispenser (GEM Runner)
5. Refill Cartridge
6. XL 201 Hair Shaper Blades B714 022 A01
7. ERGO Window Scraper 63-0629
8. 63-0226 9mm Snap off (Personna)
9. 63-0227 18mm Snap off (Personna)
10. 63-0010 4" Heavy Duty Scraper
11. 61-0420 4" Floor Scraper



## Hand Knives Range

1. SN111-9mm Snap off (H600 001 T03)
2. SN112-9mm Snap off (H601 001 T03)
3. SN115-9mm Snap off (H605 001 T03)
4. SN116 Metal 9mm (H606 001 S04)
5. SN101 18mm Snap off (H501 001 T03)
6. SN102 18mm Snap Off (H501 002 T03)
7. SN103 18mm Snap off (H501 003 T03)
8. SN104 18mm Snap off (H504 001 T03)
9. SN106 Metal 18mm Snap off (H502 001S04)
10. HT40 Plastic Scraper (H040 004 L01)
11. HT41 Metal Scraper (H041 002 A01)
12. HT42 Mini Scraper (HT42 001 A01)
13. HT9 Fixed (H009 001 N03)
14. HT14 Retractable (H014 001 N03)
15. Dolphin Knife FL-3148
16. HT28 Easy Change (H028 002 X01)
17. HT60 Carton Knife (H060 001 A03)
18. HT50 Small Metal Hobby Handle (H050 002 P03)
19. HT51 Metal Hobby Handle (HT51 002 P02)
20. HT52 Delux Hobby Handle (H052 002 A02)



## Safety Knives Range

1. Springer - right handed (H914 002 A01)
2. Springer - left handed (H914 001 A01)
3. HT8 Auto Retractable (H008 001 A03)
4. HT6 Spring Loaded Safety Cutter (H006 001 A03)
5. HT15 Spring Loaded Safety Cutter (H015 001 201)
6. Spring Loaded Roll Stripper (H016 001 J01)
7. Spring Loaded Roll Stripper Plus (H016 101 A03)
8. Spring Loaded Roll Stripper HD (H016 201 A03)
9. HT63 Spring Loaded Safety Cutter (H063 003 X01)
10. Ambi Safe Spring Loaded Safety Cutter (H944 001 T03)
11. HT30 Polyglide (H030 001 A03)
12. Polysafe Plus (H907 012 A03)
13. Supaslit (H907 003 T03B)
14. Supaslit Delux (H907 004 T03)
15. Supacut Metal (H907 013 A03)
16. HT32 Auto Retractable Squeeze Knife (H032 001 A03)



## Blade Dispensers

1. Std 100 Blade Dispenser
2. WBG 203 Injector Blade Dispenser
3. 18mm Snap-off Blade Tube
4. 9mm Snap-off Blade Tube
5. WBG 201 Single Edge Blade Dispenser
- 6a. 10 Blade Dispenser
- 6b. 10 Blade Dispenser
7. Economy Blade Dispenser



## Disposables

1. Polyslit (H913 008 T03)
2. Polyslit Plus (H913 007 S02)
3. Morri-Cut (H913 002 A02)
4. Polysafe (H907 001 X01)
5. Polysafe Blademaster (H907 016 A03)
6. Duo Slit Hook (H907 006 P04)
7. Duo Slit blademaster (H907 008 K01)
8. Ring String Cutter (H081 002 K01)
9. Split Ring String Cutter (H081 501 K01)



## Disposal Bins

1. Large Blade Disposal Bin
2. Medium Blade disposal Bin



The following products are not available to German customers or for sale/resale into Germany. Our company does not ship or distribute these products into Germany. Knife numbers: Safety knife items 1, 2, 6 and 11.  
Die folgenden Produkte werden nicht an deutsche Kunden angeboten und nicht für Verkauf oder Wiederverkauf in Deutschland. Unser Unternehmen liefert diese Produkte nicht nach Deutschland: Messer Nr. "Safety Knife" 1, 2, 6 und 11.

# Industrial Blades

Durham-Duplex's "Made in Sheffield" credentials confirm it as one of the world's best industrial razor blade manufacturers. By making precision ground strip to the most exacting tolerances the company's products are able to cope with the demands of modern production methods and all trade requirements. We offer an extensive standard blade range in carbon, stainless and high grade alloys, complemented by the latest in long life, low friction PVD coatings, powder technology carbide and ceramic blades. In addition, our utility range can be supplied *branded* with your company name and logo, on the body, the blade or the packaging and is offered in a selection of presentation, utilitarian and safety packaging.

**WBG 207** Thickness .025"/0.64mm  
**WBG 207C** Thickness .025"/0.64mm  
**WBG 208** Thickness .025"/0.64mm  
**WBG 208C** Thickness .025"/0.64mm  
**WBG 206** Thickness .017"/0.43mm  
**WBG 207 3N 5H** Thickness .025"/0.64mm  
**WBG 207XL** Thickness .025"/0.64mm  
**WBG 208F Flat Face Safety Hooked Blade** Thickness .025"/0.64mm  
**WBG 209** Thickness .025"/0.64mm  
**WBG 209C** Thickness .025"/0.64mm  
**WBG 206 3N 5H** Thickness .017"/0.43mm  
**WBG 202R Carbon Steel** Thickness .005" .008" .010" .015"/0.13mm 0.20mm 0.25mm  
**WBG 202S Carbon Steel** Thickness .004" .006" .008" .010"/0.10mm 0.15mm 0.20mm 0.25mm 0.3mm  
**WBG 204 Stainless Steel** Thickness .004"/0.10mm  
**WBG 203 Carbon or Stainless Steel** Thickness .010"/0.25mm  
**WBG 201 WITHOUT SPINE** Carbon Steel Thickness .009"/0.23mm  
**WBG 201 WITH SPINE** Carbon or Stainless Steel Thickness .009"/0.23mm  
**WBG 213** Thickness .025"/0.64mm  
**WBG 214** Thickness .017"/0.43mm  
**WBG 215 WALL SCRAPER BLADE** Thickness .017"/0.43mm  
**"SNAP-OFF" SEGMENTAL & NON-SEGMENTAL BLADES**  
**SNB 100** Thickness 0.20"/0.5mm  
**SNB 110** Thickness .015"/0.38mm  
**SNB 100** Thickness 0.020"/0.5mm  
**SNB 110** Thickness .015"/0.38mm  
**"SLIMKNIFE" TYPE BLADES**  
**"SURGICAL" BLADES AND HANDLES**  
**ALL TO SUIT HANDLE N° 3**  
**ALL TO SUIT HANDLE N° 4**  
**FIBREGLASS CHOPPER BLADES**  
**Specials**  
**Not to scale**



As well as being manufacturers of  
Machine knives and Industrial blades  
we are proud to be



Durham Duplex  
also handle distribution for



THE DURHAM DUPLEX PRODUCT RANGES, SUITABLE FOR ALL CUTTING,  
SLITTING, CHOPPING, PERFORATING AND SCRAPING APPLICATIONS, ARE  
THE MOST COMPREHENSIVE AVAILABLE. HOWEVER, YOU MAY HAVE A  
REQUIREMENT FOR AN ITEM NOT SHOWN ON OUR LITERATURE, BUT

WHICH FITS OUR GENERAL PRODUCT GROUPINGS, IF SO:-

**PLEASE SEND DETAILS AS WE WILL ALMOST CERTAINLY  
BE ABLE TO SUPPLY**



312-314 PETRE STREET, SHEFFIELD S4 8LT. ENGLAND.  
TEL: +44 (0) 114 243 2313 FAX: +44 (0) 114 244 4329  
Email: [sales@durham-duplex.co.uk](mailto:sales@durham-duplex.co.uk)  
Website: [www.durham-duplex.com](http://www.durham-duplex.com)

